

SPRAY RIGS CATALOG



SPECIALISTS IN LIQUID
HANDLING PRODUCTS

EST. 1983

ABOUT CCI



We have over 65,000 square feet of manufacturing and warehousing space with an additional 16 acres of facilities and bulk tank inventory. This allows us to fill your order and ship the same day.



Our experienced, knowledgeable, and friendly staff will assist you with any of your questions and needs!

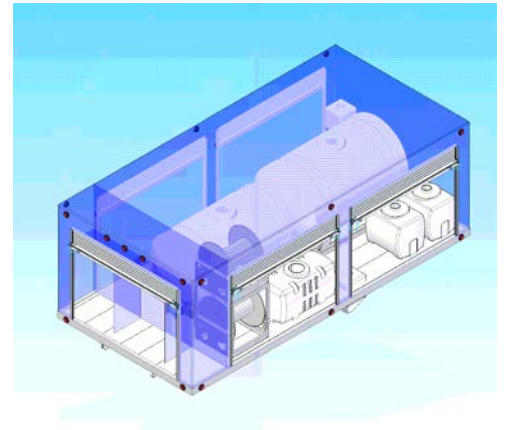

- Custom CAD design for spray equipment and liquid handling systems.
- Specialty welding of stainless steel, aluminum, and polyethylene.
- Complete service, repairs and maintenance.
- Over 15,000 items in stock for same day delivery.
- 6 mobile sales people to provide you with on-site assistance.

"Specialists In Liquid Handling Products & Equipment"
413 ABC Rd., • Lake Wales, FL. 33859
Sales 800-346-7867 • Fax 863-638-1863
www.chemicalcontainers.com

TABLE OF CONTENTS

Truck Galleries.....	1-2
Chassis Options	3
Aluminum Box Options.....	4
Aluminum Box Examples	5
Tank Options	6
Honda Engines.....	7
Udor Pumps	8
Truck Features.....	9
Parts	10
Skid Gallery	11-12



TRUCK GALLERY



TRUCK GALLERY



CHASSIS OPTIONS



Isuzu NQR

5.2 liter Isuzu 4HK1-TC turbo-charged intercooled diesel
215 HP / 452 lbs/ft Torque
Payload: 10,939-11,461 lbs
GVWR: 17,950
Front GAWR: 6,830 lbs
Rear GAWR: 12,980 lbs



Isuzu NRR

5.2 liter Isuzu 4HK1-TC turbocharged intercooled diesel
215 HP / 452 lbs/ft Torque
Payload: 12,294-12,838 lbs
GVWR: 19,500
Front GAWR: 7,275 lbs
Rear GAWR: 13,660 lbs



Ford F-550

6.7L Power Stroke® V8 Turbocharged Diesel
330 HP / 750 lbs/ft Torque
Payload: 12,730 lbs
GVWR: 19,500
Front GAWR: 7,500 lbs
Rear GAWR: 14,706 lbs



Kenworth T-270

P6.7L PACCAR PX-7 Diesel
325 HP / 750 lbs/ft Torque
Payload: 12,730 lbs
GVWR: 26,000
*Available as non-CDL truck
Front GAWR: 10,000 lbs
Rear GAWR: 16,000 lbs

ALUMINUM BOX OPTIONS

- Open or all enclosed body styles
- All welded unitized aluminum structure with aircraft grade aluminum bodies
- PTO or Honda driven pumps for tree and or lawn spraying applications
- Structural decking for maximum load capacity
- Curbside operator controls
- DOT - LED lighting and safety strobe lights
- Dover aluminum locking roll-up doors
- Custom interior shelving and dividers
- High pressure jet agitation available
- Stainless steel control manifolds
- Epoxy primer coat with chemical resistant, industrial grade, polyurethane enamel finish
- Complete user's manual and full 1 year warranty

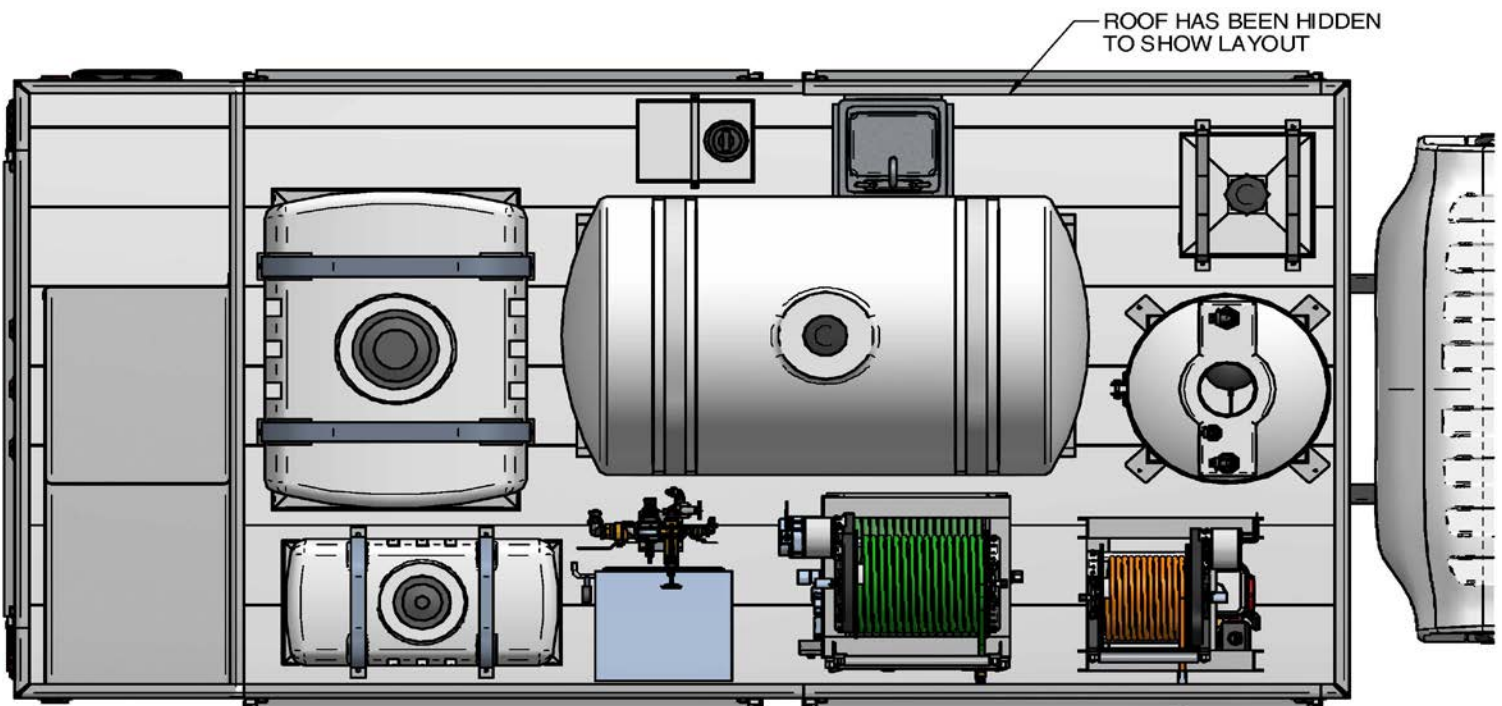

Fuel Tanks



Wash Stations



Overhead Lights



Tool Boxes



ALUMINUM BOX EXAMPLES

NOTES: ROOF PANELS HAVE BEEN HIDDEN TO SHOW LAYOUT

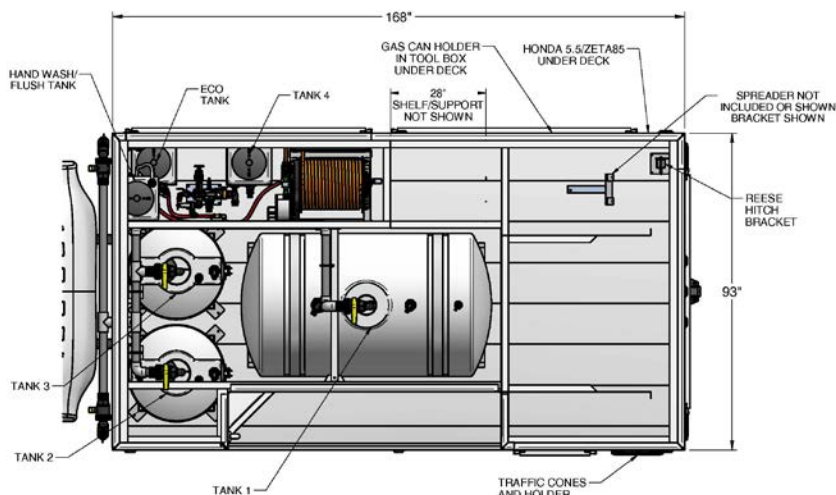

- Custom CCI truck sprayer
- 3 polyethylene tanks
- 1 electric hose reel
- Stainless steel manifold
- Hand washing station
- Honda engine for pump
- Under body storage
- In box storage
- 5 roll down doors
- Storage area for spreader

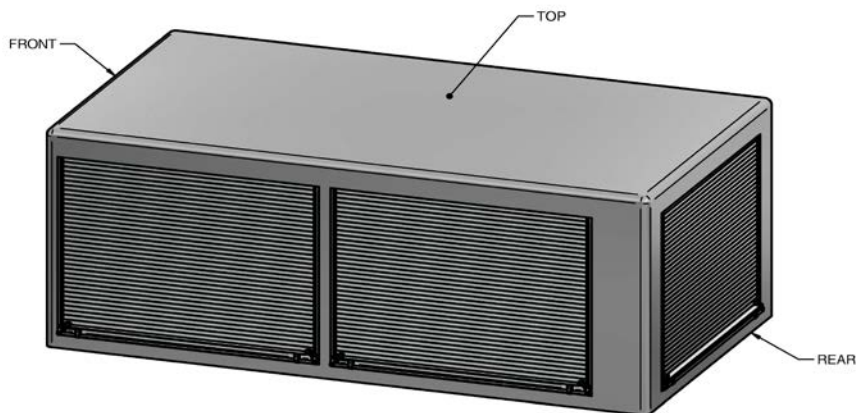

- Custom CCI truck sprayer
- Basic box design
- Multiple door number and placement options
- Can be outfitted with almost any option
- Open top or fully enclosed boxes

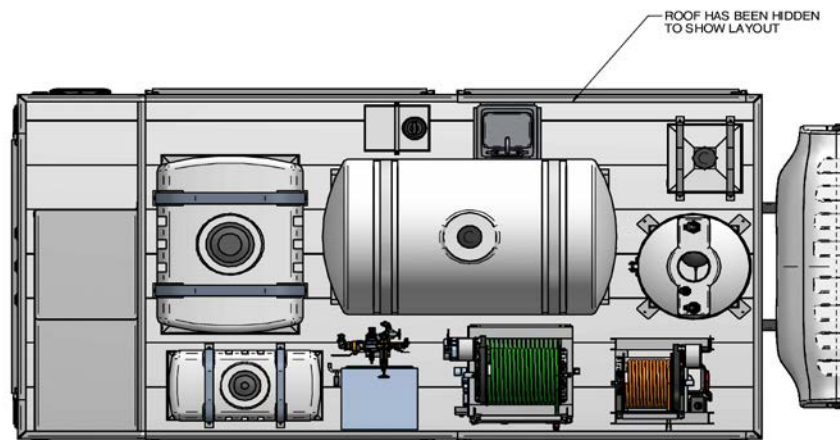

- Custom CCI truck sprayer
- 4 polyethylene tanks
- Stainless steel manifold
- 2 electric hose reels
- 1 chemical feed tank 5gal
- Custom hand washing sink
- Rear storage for chemicals
- 5 roll down doors

TANK OPTIONS

Chemical Containers Inc uses high quality polyethylene tanks for commercial spray rig applications. The tanks can hold a variety of chemicals and are very resistant to the rigors of commercial work environments. Chemical Containers spray rigs use vertical tanks, horizontal applicator tanks, PCO tanks, cone bottom tanks, total drain tanks, and a stainless steel mix hopper.

Vertical Tanks

- Polyethylene
- 20 to 150 gallons
- Nurse tank
- Chemical Mixing
- Chemical storage

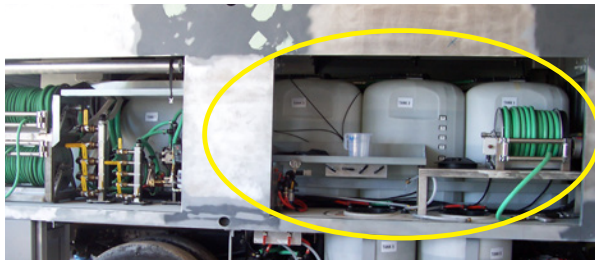

Horizontal Applicator Tank

- Polyethylene
- 12 to 500 gallons
- Nurse tank
- Chemical mixing tank
- Chemical storage



PCO Tanks

- Polyethylene
- 30 to 300 gallons
- Chemical application
- Ribbed for extra strength

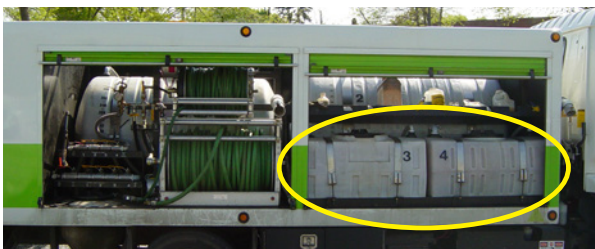

Total Drain and Cone Tanks

- Polyethylene
- 5 to 110 gallons
- Chemical feed
- Hand wash tank

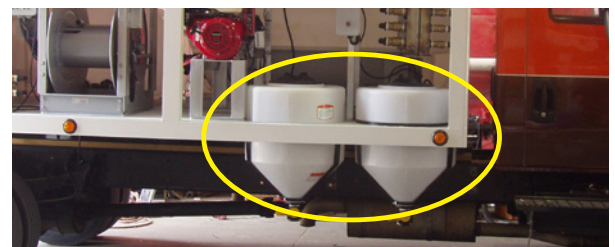

Stainless Steel Hoppers

- Stainless steel
- 5 gallons
- Pulls dry chemical into tanks



HONDA ENGINES



GX 690

- 22.1 Horsepower
- Electric start
- 97 lbs
- Alternate fuel tank



GX 670

- 20.5 Horsepower
- Electric start
- 97 lbs
- Alternate fuel tank



GX 630

- 18 Horsepower
- Electric start
- 97 lbs
- Alternate fuel tank



GX 390

- 11.7 Horsepower
- Pull or electric start
- 6.7 U.S. qts fuel tank capacity
- 79 lbs



GX240

- 7.9 Horsepower
- Pull or electric start
- 5.6 U.S. qts fuel tank capacity
- 55 lbs



GX160

- 4.8 Horsepower
- Pull or electric start
- 3.3 U.S. qts fuel tank capacity
- 33 lbs

* Other pump and engine options available



UDOR PUMPS



KAPPA-150

- 42 GPM Max/ 700 PSI Max
- Four diaphragm pump w/ pulsation dampener and control unit w/ pressure regulator, manual dump level and pressure gauge.



KAPPA-120

- 35 GPM Max/ 700 PSI Max
- Four diaphragm pump w/ pulsation dampener and control unit w/ pressure regulator, manual dump level and pressure gauge.



KAPPA-100

- 26 GPM Max/ 560 PSI Max
- Four diaphragm pump w/ pulsation dampener and control unit w/ pressure regulator, manual dump level and pressure gauge.

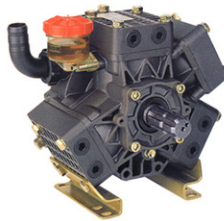

KAPPA-75

- 20 GPM Max/ 560 PSI Max
- Three diaphragm pump w/ universal drive face, pulsation dampener and control unit w/ pressure regulator, manual dump level, dual ball valve outlets and pressure gauge.



KAPPA-40

- 10.5 GPM Max/ 560 PSI Max
- Three diaphragm pump w/ universal drive face, pulsation dampener and control unit w/ pressure regulator, manual dump level, dual ball valve outlets and pressure gauge.



KAPPA-18

- 4.2 GPM Max/ 70 PSI Max
- Two diaphragm pump w/ pulsation dampener.
- Equipped with 12V DC motor

TRUCK FEATURES

Easy To Use Electric Hose Reels



Dover Locking Roll-Up Doors



Chemical Mixing Eductor



Easy To Operate Controls



Wide Selection Of Spray Guns



PARTS

POLY FITTINGS



FLANGE FITTINGS



STAINLESS FITTINGS



BANJO FITTINGS



PVC FITTINGS
SCHEDULE 40 & 80



REGULATORS & GAUGES



QUICK COUPLERS/BRASS FITTINGS



HOSES



STRAINERS



TANK FITTINGS



SPRAY GUNS



HOSE REELS

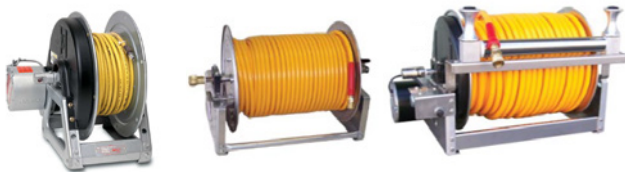

SPECIALTY PARTS



SKID GALLERY

Skids are a great way to add versatility to your operation!



SKID GALLERY

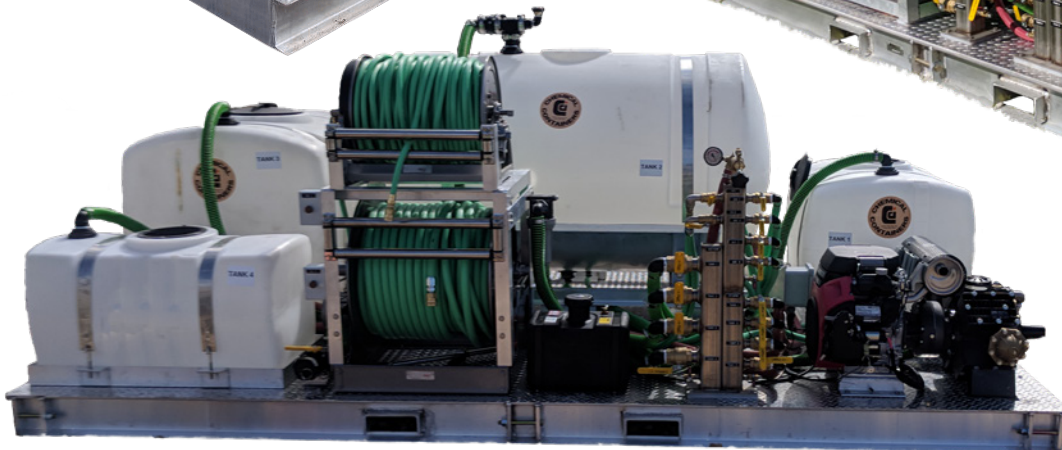
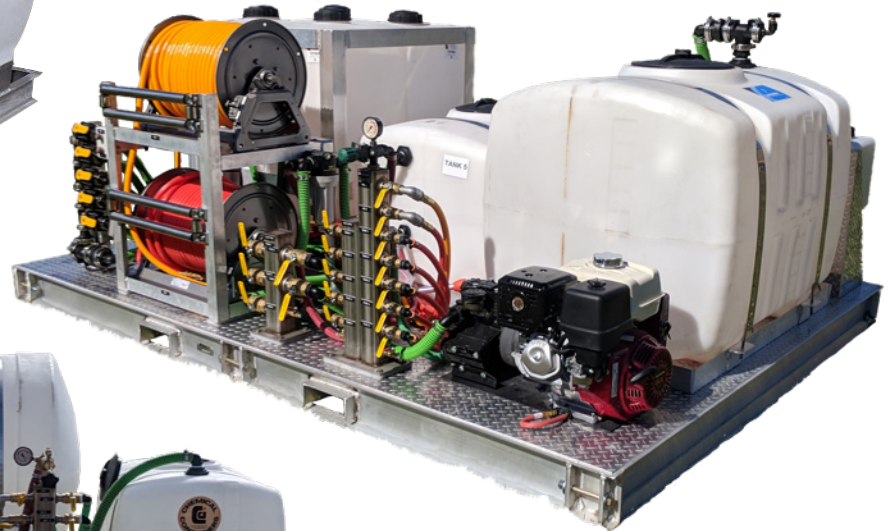

SPECIALISTS *IN LIQUID* **HANDLING PRODUCTS**

EST. 1983



413 ABC Road
Lake Wales, FL 33859-6849
Phone - 863-638-1407/ Fax - 863-638-1863/ WATS 800-346-7867
Sales@chemicalcontainers.com

Amber Baldi
Sales Rep.
Office: 863-638-1407 Ext. 150
Cell: 863-241-3952
abaldi@chemicalcontainers.com

John Larr
Commercial Spray Rig Dept. Manager
Office: 863-638-1407
Cell: 863-528-8129
jlarr@chemicalcontainers.com

**Call or email our friendly and experienced sales team today for
your custom spray truck!**